

(No Model.)

5 Sheets—Sheet 2.

C. H. GOODRICH.

MACHINE FOR FINISHING COCKS AND VALVES.

No. 270,052.

Patented Jan. 2, 1883.

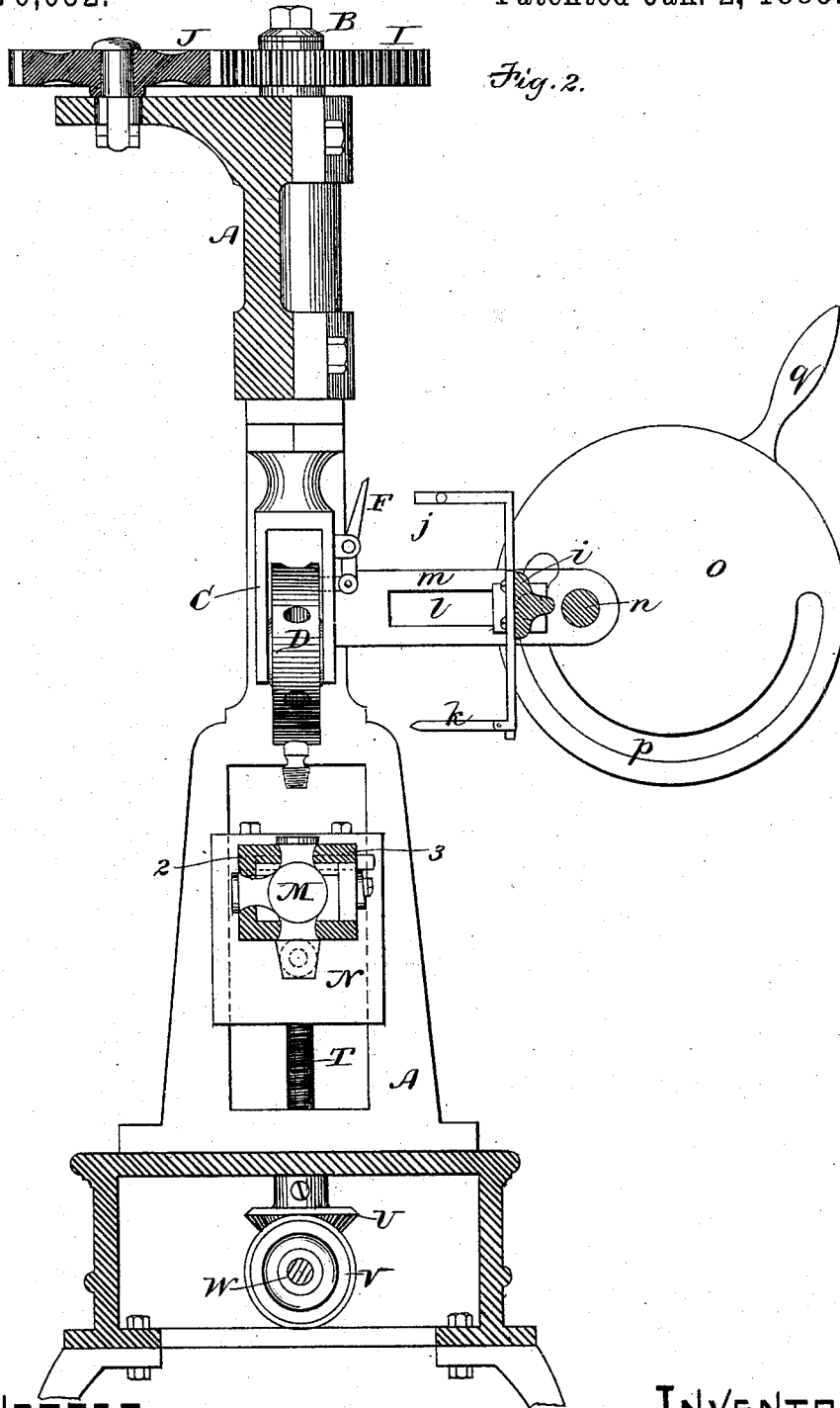

Fig. 2.

WITNESSES.

Joseph Baker
A. L. White.

INVENTOR.

C. H. Goodrich
by *myself* or *some*
Atty.

(No Model.)

5 Sheets—Sheet 3.

C. H. GOODRICH.

MACHINE FOR FINISHING COCKS AND VALVES.

No. 270,052.

Patented Jan. 2, 1883.

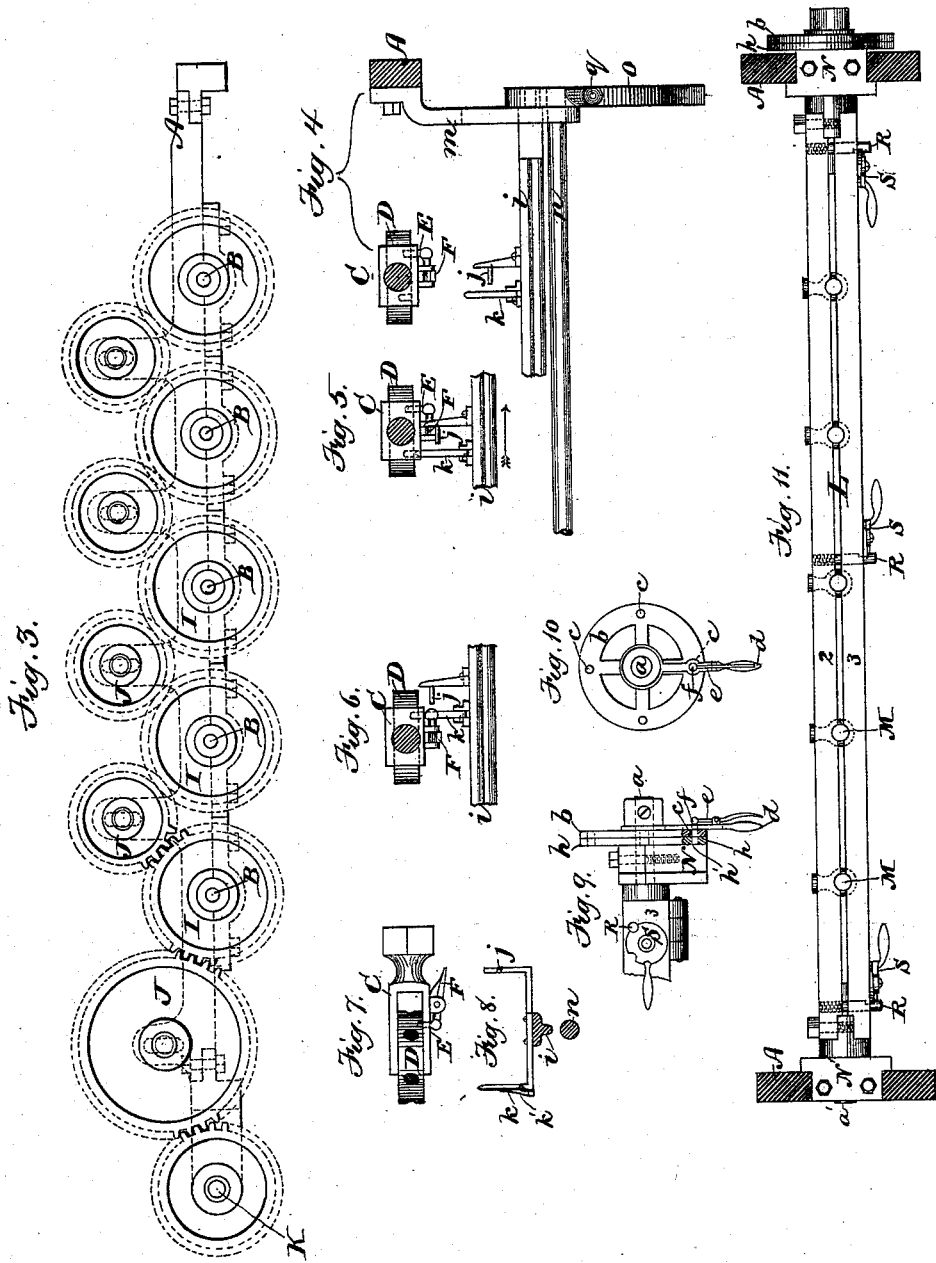

WITNESSES.

*Joseph Lenthin
ex. d. white*

INVENTOR.

*C. H. Goodrich
by *Night & Brown*
Atty.*

(No Model.)

5 Sheets—Sheet 4.

C. H. GOODRICH.

MACHINE FOR FINISHING COCKS AND VALVES.

No. 270,052.

Patented Jan. 2, 1883.

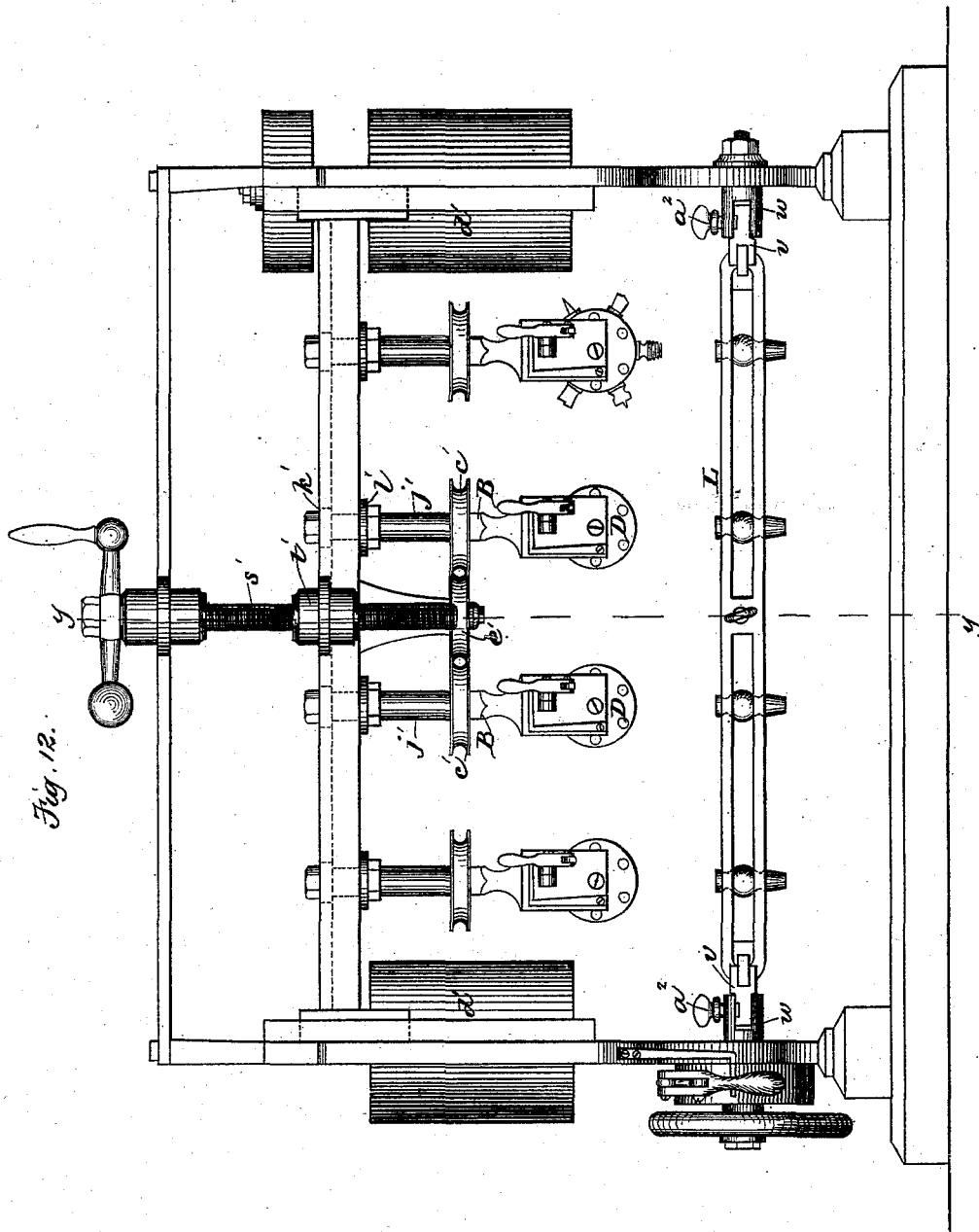

Fig. 12.

WITNESSES.

Joseph Lantier
A. L. White.

INVENTOR.

C. H. Goodrich
by Wright & Brown
Atty.

C. H. GOODRICH.

MACHINE FOR FINISHING COCKS AND VALVES.

No. 270,052.

Patented Jan. 2, 1883.

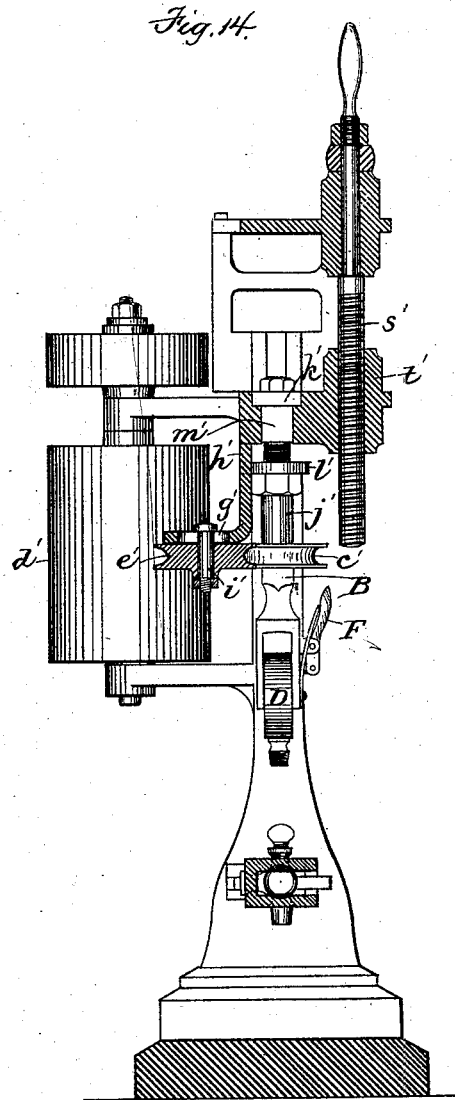
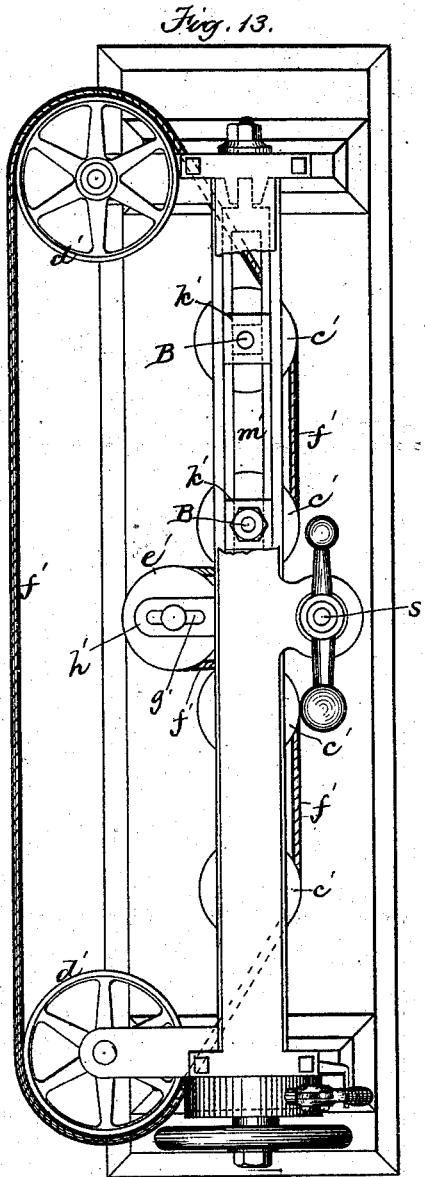

WITNESSES.

Joseph Leutler
A. L. White

INVENTOR.

C. H. Goodrich
by *Wm. H. Brown*
Atty.

UNITED STATES PATENT OFFICE.

CHARLES H. GOODRICH, OF STONEHAM, MASSACHUSETTS.

MACHINE FOR FINISHING COCKS OR VALVES.

SPECIFICATION forming part of Letters Patent No. 270,052, dated January 2, 1883.

Application filed August 16, 1882. (No model.)

To all whom it may concern:

Be it known that I, CHARLES H. GOODRICH, of Stoneham, in the county of Middlesex and State of Massachusetts, have invented certain
5 Improvements in Machines for Finishing Cocks and Valves, of which the following is a specification.

This invention relates to machines for simultaneously drilling holes in a series of objects,
10 and has for its object to provide a machine adapted to drill and tap a series of gas cocks or valves or other like articles requiring to be drilled and tapped at two or more points or ends.

My invention consists as a whole in the combination of a series of positively-rotated turrets or tool-holders having suitable drilling and tapping tools, a rotary clamp or holder adapted to hold a series of cocks or valves in
20 position under the operating-tools, means for locking said clamp in as many different positions as there are branches on the cocks or valves to be acted on by the tools, and means for presenting the series of cocks or valves
25 simultaneously to the tools.

The invention also consists in the provision of means for simultaneously rotating all the tool-holding turrets to bring a different tool in each turret into operative position when required, and in certain details of construction,
30 all of which I will now proceed to describe and claim.

Of the accompanying drawings, forming a part of this specification, Figure 1 represents a front elevation of a machine embodying my
35 invention. Fig. 2 represents a transverse vertical section on line *x x*, Fig. 1. Figs. 3, 4, 5, 6, 7, 8, 9, 10, 11 represent details of the machine shown in Fig. 1. Fig. 12 represents a front elevation of a similar machine, adapted for lighter work. Fig. 13 represents a top
40 view of the same. Fig. 14 represents a vertical section on line *y y*, Fig. 12.

The same letters of reference indicate the
45 same parts in all the figures.

In the drawings, A represents the supporting-frame of the machine, in which are journaled a series of arbors, B, each having at its lower end a turret-holder, C, in which is pivoted a turret, D, of ordinary construction, hav-

ing a suitable number of drilling and tapping tools, and locked to the holder by a pin, E, pivoted to a spring-lever, F, which is pivoted to the holder C, the pin E passing through an orifice in the holder and entering one of a series of orifices, G, in the turret. The arbors B are rotated simultaneously by any suitable means, preferably by a series of gears, I I, on said arbors and intermediate gears, J, all driven by a driving-shaft, K, having suitable pulleys,
60 although for light work the arbors may be driven by a single belt passed around pulleys on said arbors, or by a series of independent belts, as hereinafter described.

L represents a holder adapted to hold a series of cock or valve bodies, M, in position under the turrets. Said holder is composed of a bar, 2, attached at its ends to slides N N', which are supported by the frame of the machine, as hereinafter described, and a bar, 3,
70 which is movable toward and from the bar 2. Said bars are provided with sockets or jaws in their proximate surfaces, adapted to fit snugly against the outer surfaces of the cock or valve bodies, and have longitudinal slots P to receive one of the parts or arms of each body,
75 as shown in Fig. 2. The bar 2 has a series of studs, R, projecting through orifices in the bar 3, and provided with slots in their outer ends.

To the bar 3 is pivoted a series of cams, S,
80 projecting into the slots in the studs R, and adapted, when turned on their pivots in one direction, to clamp the bars 2 3 tightly against the cock or valve bodies interposed between said bars, and when turned in the opposite
85 direction to permit the separation of said bars and the removal of the cock or valve bodies. The holder L is supported by the slides N N', to which the bar 2 is attached, as above described. Said slides are adapted to move in
90 vertical guides or slots in the frame A. T T represent vertical screw-shafts, journaled in the frame A and entering tapped sockets in the slides N N'. Said screw-shafts are provided with bevel-gears U U, which mesh with similar gears, V V, on a horizontal shaft, W, which has a crank, X. By rotating said shaft the slides N N' and holder L are lifted, and the cock or valve bodies, held by the holder, are presented simultaneously to the operating-tools
100

in the turrets and drilled or tapped thereby, as the case may be. When the operation is completed the slides and holder are lowered and the holder is rotated in the slides $N N'$, so as to bring the next arm or end of the cock or valve bodies into position to be drilled or tapped.

The bar 2 of the holder is provided with trunnions aa' , which are journaled in the slides $N N'$, and thus permit the rotation of the holder L. To the trunnion a is rigidly attached a disk or plate, b , having a series of orifices, c , corresponding in number to the number of positions in which the holder L is to be locked and held for the action of the tools. In this case three positions are to be assumed by the holder, the cock or valve bodies having to be drilled at three ends. Hence the disk is provided with three orifices, c .

The trunnion a is provided with a handle or lever, d , to which is pivoted a spring-lever, e , having pivoted to one of its ends a locking-pin, f , the latter being forced by the spring-lever into one of the orifices c of the plate b when the pin coincides with said orifice. A plate, h , having a single orifice, h' , is rigidly attached to the slide N by the side of the plate b , and its orifice is arranged to receive the locking-pin f when the latter, already inserted in an orifice, c , of the plate b , is brought to the orifice h' of the plate h by the rotation of the plate b and holder L. The insertion of the pin f into the orifice h' locks the holder L, and when it is desired to again partially rotate and lock said holder the pin f is withdrawn from the plates h and b and moved by the handle to the next orifice c in the plate b , into which the pin springs. The handle d is then moved down until the pin springs into the orifice h' and again locks the holder.

It will be seen from the foregoing that the general operation is as follows: The cock or valve bodies are secured in the holder. The latter is locked in the desired position and raised to present the holders to the rotating tools in the turrets. After the action of the tools is completed the holder is lowered and partially rotated to bring the portions of the cock or valve bodies next to be drilled or tapped into position under the tools and locked in the position thus assumed, and again raised, and so on until the desired operations have been performed on the bodies M. When it is desired to rotate the turrets D so as to bring a new tool in each turret into operative position, I prefer to employ mechanism for adjusting all the turrets simultaneously. The mechanism illustrated is composed of a horizontal bar, i , arranged beside the series of turrets, and provided with a series of fixed arms, j , and a series of pivoted fingers, k , said arms and fingers projecting toward the turrets. The bar i is supported at its ends in horizontal slots l in fixed arms m , attached to the frame A, and is movable laterally or toward and from the turrets in said slots. In said arms m is journaled a

shaft, n , having at its ends two rigidly-attached eccentric disks, oo , having eccentric grooves p , into which the ends of the bar i project. The disks o are provided with handles q , by which they may be rotated. When the disks are rotated the grooves p act on the bar i and move said bar toward or from the turrets D, according to the direction of rotation. The bar i is capable of being moved longitudinally by the operator in either direction, and is provided with a handle, r , for this purpose. The operation of this mechanism is as follows: The operator turns the disks o , so as to move the bar i toward the turrets, the latter presenting their apertured sides to the bar, as shown in Figs. 1, 2, 4, 5, 6, and 7. This movement causes the arms j to bear against the outer ends of the levers F of the turrets and move said levers, so as to withdraw the locking-pins E and the fingers k to enter the unoccupied orifices G in the turrets, as shown in Fig. 5. The operator then grasps the handle r and moves the bar i longitudinally in the direction indicated by the arrow in Fig. 5 to the position shown in Fig. 6, the fingers k being thus caused to give the turrets a partial rotation and bring a new tool on each turret into operative position. The operator then moves the bar i away from the turrets. The fingers k are pivoted so as to rise and fall at their outer ends, as required, by the rotation of the turrets, while the fingers are inserted in the orifices thereof, and are provided with springs k , which normally hold the fingers upwardly and permit them to swing downwardly.

The bar or jaw 3 of the holder L may be connected to the bar 2 by hinges $t t$, as shown in Fig. 1, or by dovetail ribs uu on one of said parts, fitted in corresponding grooves in the other part. In some cases I prefer to make the holder L adjustable laterally; and to this end I provide the holder at its ends with slides vv , which are fitted to move grooved blocks ww , attached to the frame A, said slides being held in place at any position to which they may be adjusted by set-screws $a^2 a^2$. When the machine is intended for light work the tool-holders may be driven by a belt or belts instead of by gears. The construction shown in Figs. 12, 13, and 14 represents each arbor B as provided with a pulley, e' . These pulleys may, if desired, be driven by separate belts; but I prefer to drive them by a single belt, running on two end pulleys, $d' d'$, and a central pulley, e' , placed about midway of the series of arbors. The pulleys $d' d'$ and e' are offset, as shown in Fig. 13, so that the belt f' runs against one side of each pulley, and all the tools are rotated in the same direction by the belt. The central pulley is made adjustable by means of a slot, g' , in the standard h' , in which said pulley is journaled, and an attaching-bolt, i' , passing through said slot. The adjustability thus afforded enables the belt to be tightened as may be desired. The arbors b , when provided with pulleys, are preferably

journalled in sleeves j' , which are provided with shoulders k' and clamping-nuts l' , which bear respectively against shoulders formed on the sides of a slot, m' , in the frame A, and confine the sleeves rigidly at any point to which they may be adjusted in the slot m' .

It will be seen that provision is made for the independent lateral adjustment of the arbors and their tools, so as to enable two or more holes to be drilled by each tool in a body held in the holder L.

I do not limit myself to raising and lowering the holder L to present the cock or valve bodies to the tools, for, if desired, the part of the frame A by which the arbors B are supported may be vertically movable in guides formed on the fixed part of the frame, as shown in Fig. 12, and adjusted vertically by means of a screw, s' , working in a nut, t' , on said movable part, or by any other suitable means.

I am aware that a turret holding a radiating series of tools has been pivoted to a fixed support in a lathe and locked in different positions by a locking-pin; but I am not aware that such a turret has ever been journalled in a support or holder formed on a rotary arbor, as hereinafter claimed.

I claim—

1. The combination of a series of two or more tool-holders simultaneously rotatable and a corresponding series of clamping-jaws or holders arranged to coincide with the tools in the tool-holders and adapted to hold cock or valve bodies for the action of said tools, as set forth.

2. The combination of a series of rotatable tool-holders, a rotatable clamp or holder adapted to hold a series of cocks or valves in position under the tool-holders, means for locking said clamp in different positions, and means for presenting the series of cocks or valves simultaneously to the tools in the tool-holders, as set forth.

3. A series of holders for the cocks or valves composed of two separable bars, clamps, or jaws having cavities adapted to fit snugly against the cocks or valves interposed between them, and means for clamping said bars against the interposed cocks or valves, as set forth.

4. The holder composed of the socketed bar 2, provided with means for connection with the frame of the machine, and provided with slotted studs R and the correspondingly-socketed bar 3, having orifices to receive said studs, and cams S to engage with the studs and clamp said bars against the interposed cocks or valves, as set forth.

5. The combination of the series of rotatable turrets or tool-holders, the cock or valve holder located under said tool-holders, and means for raising and lowering said cock or valve holder to present and withdraw the series of cocks or valves simultaneously to and from the tools, as set forth.

6. The combination, with the series of tool-holders, of the cock or valve holder, and means for adjusting the same laterally, as set forth.

7. The combination, with the series of rotary turrets having suitable tools radially arranged, of mechanism for simultaneously rotating said turrets on their pivots to bring a different tool on each turret into operative position, as set forth.

8. The combination, with the rotary turrets having the side orifices, the turret-holders having the locking pins and levers F operating said pins, the bar i , having arms j and fingers k , and means, substantially as described, whereby said bar may be moved inwardly to cause the arms j to bear on the levers F, withdraw the locking-pins from the turrets, and insert the fingers k into unoccupied orifices in the turrets, then longitudinally to partially rotate the turrets, and then outwardly to withdraw the arms and fingers from the turrets, as set forth.

9. The combination of the frame A, having the longitudinal slot m' , the series of sleeves located in said slot, the tool-holder arbors journalled in said sleeves and provided with pulleys e' , and means for adjusting said sleeves in the slot and positively holding them in any position to which they may be adjusted, whereby the lateral adjustment of the tools is effected, as set forth.

10. The combination, with the series of tool-holder arbors having pulleys e' , of the adjustable belt-tightening pulley e' , located midway of said arbors, and the end pulleys, $d' d'$, arranged as described, whereby all the arbors are rotated in the same direction by a single belt, as set forth.

In testimony whereof I have signed my name to this specification, in the presence of two subscribing witnesses, this 12th day of August, 1882.

CHAS. H. GOODRICH.

Witnesses:

C. F. BROWN,
A. L. WHITE.